

Telescopic Soft Seal Gate Valve

SZ45X-10Q/16Q

This valve based on a traditional soft-seal gate valve, an additional telescopic flange, the valve installation length can be within a certain range of free expansion and contraction, convenient for installation and construction.

Performance Parameter

Nominal Pressure: 1.0/1.6MPa
Applicable Temperature: 0~80° C
Applicable Medium: Water, Sewage

Main Components

Part Name: Material
Valve body: Nodular cast iron
Valve cover: Nodular cast iron

FEATURES

- One end of the flange can be freely expanded and contracted, convenient for installation and maintenance, eliminating pipe deformation and stress.
- Limit screw can prevent the flange from pulling off.
- The valve stem is sealed by three "O" type sealing rings, maintenance free.
- The gate plate is fully covered with rubber, reliable sealing, zero leakage.
- Rubber plate mold molding, good interchangeability, convenient maintenance and replacement.



The design, materials and specifications are subject to change without notice. This is due to continuous development

Main Components

Main Components	
Valve body:	Nodular cast iron
Valve cover:	Nodular cast iron
Switchboard:	Nodular cast iron
Plywood:	NBR/EPDM
Tappet:	Stainless Steel
O - Sealing ring:	Nitrile rubber
Valve stem nut:	Copper alloy

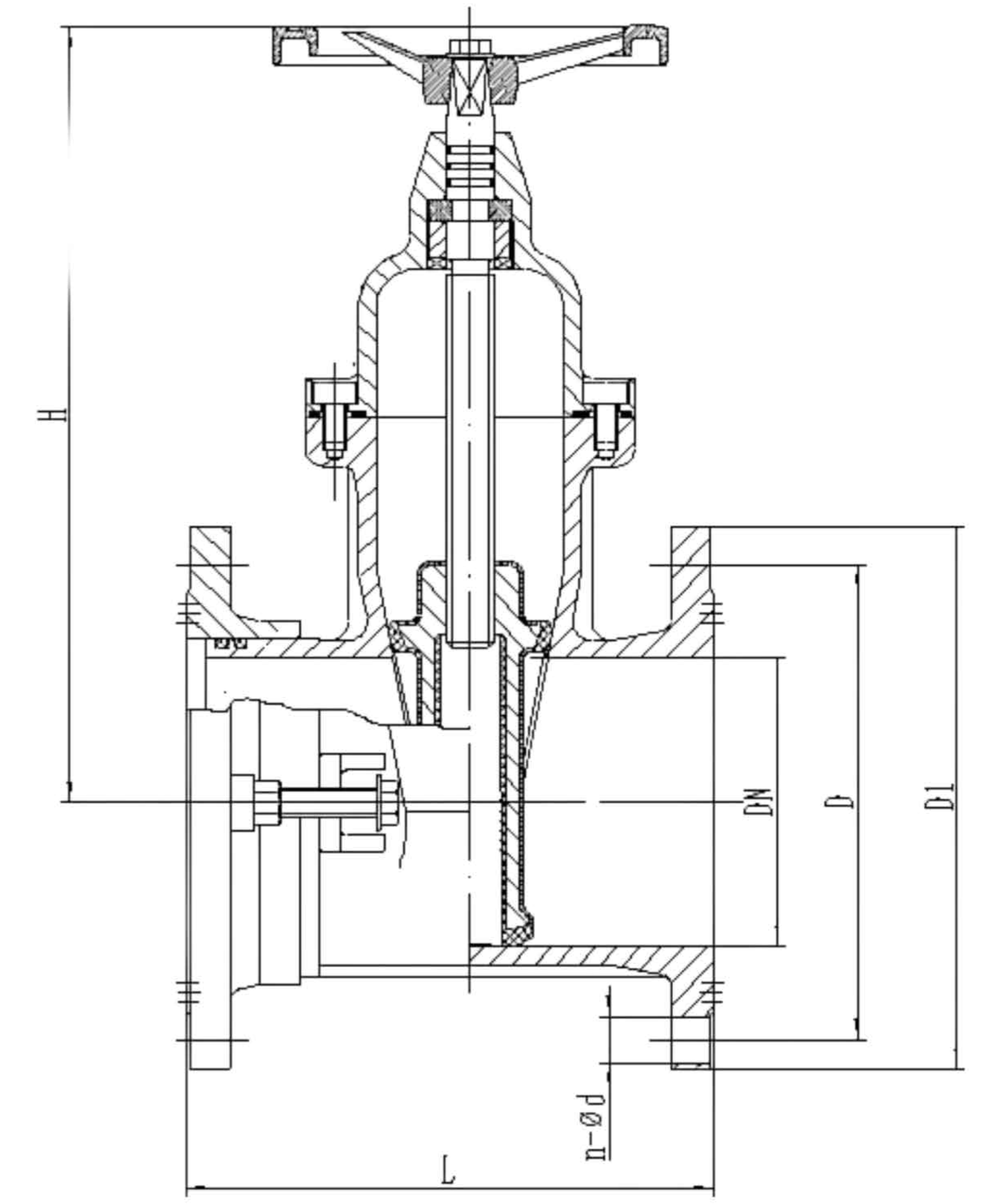

Installation Dimension Unit : mm

DN	L			D	D1	1.0		H
	Standard	Max	Min			(n - φd)	(n - φd)	
50	178	198	168	165	125	4 - φ19	4 - φ19	178
65	190	210	180	185	145	4 - φ19	4 - φ19	210
80	203	223	193	200	160	8 - φ19	8 - φ19	270
100	229	249	219	200	180	8 - φ19	8 - φ19	310
150	267	287	257	285	240	8 - φ23	8 - φ23	395
200	292	312	282	340	295	8 - φ23	8 - φ23	493



The design, materials and specifications are subject to change without notice. This is due to continuous development