

Expandable copper gate valve

SZ15W-16T

Expandable copper gate valve is mainly composed of body, valve cover, valve stem, gate plate and other parts. The valve shaft adopts a unique sealing structure, and the valve is easy to open and close. Widely used in water supply, gas supply and other pipelines, used to control and cut off the medium.

Performance Parameter

Nominal pressure: 1.6MPa
Suitable temperature: 0-80 °C
Suitable medium: Water

Main Components

Valve body: Brass
Bonnet: Brass
Ram: Brass
Seat Seal

FEATURES

- Light valve switch.
- Highly sealed, zero leakage.
- The valve shaft is sealed with "O" sealing ring, maintenance free.
- Can be sealed bidirectional.
- Suitable for water, heating, fire, petrochemical, food and other industries.



The design, materials and specifications are subject to change without notice. This is due to continuous development

Main Components

Main Components	
Valve body	Brass
Bonnet	Brass
Ram	Brass
Stem	Brass
O - seal ring	Nitrile rubber/EPDM

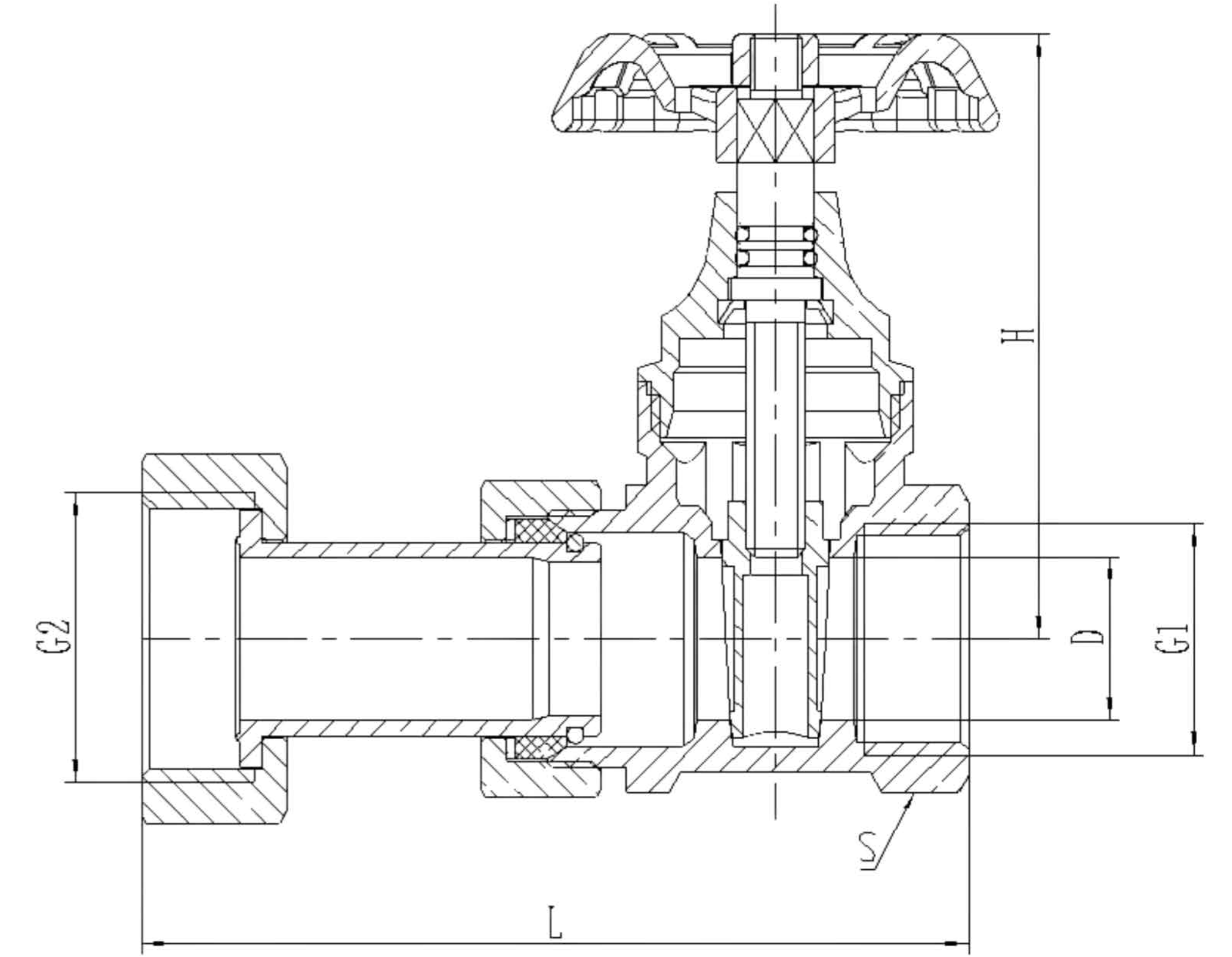

Installation Dimension Unit : mm

Nominal Diameter	G	Brass Gate Valve	L		S	H
			Max L	Min L		
15	1/2"	42	80	70	25	58
20	3/4"	45	83	72	31	62
25	1"	52	/	/	38	69
32	1 1/4"	55	/	/	47	80
40	1 1/2"	60	/	/	54	90
50	2"	70	/	/	65	100



The design, materials and specifications are subject to change without notice. This is due to continuous development